

# **POLIVAC SL1600 DOMINATOR ULTRA HIGH SPEED POLISHER**



**Operations Manual & Trouble Shooting Guide**

# How to Operate an SL1600 Dominator or SL2000 Stingray



Please find the following correct procedure for the operation of the Polivac SL1600 Dominator or a SL2000 Stingray.

1. Ensure that the power is on, and that extension cords are not used.
2. The handle height must be adjusted to suit individual operators body proportions. Adjust the ergo handle, to the correct height by placing the foot or hand on the ratchet lever then positioning the handle. The correct height of the handle is around the groin region.
3. When the handle is set at the correct height, the arms should grip the handle in a comfortable, but loose manner (if your arms are bent at the elbows this is an indication that you are applying too much effort to control the machine) Re-adjust the handle.
4. Before starting the motor, you must tilt the machine back by gently pressing down on the handle. Ensure the pad is clearly off the floor, doing this reduces the starting torque load on the motor.
5. To start the machine, first you must depress the red safety button that is next to the hand trigger, then grasp either of the red triggers, and the motor will engage the pad. Do not force the trigger without first releasing the safety button as this will damage the safety release in the trigger mechanism. Once the machine is on, the safety button can be released.
6. Once the motor has started, engage the pad on the floor and begin walking behind the machine.
7. Always work away from the cord and in a straight-line direction (do not try to swing machine side to side) then complete a U-turn and continue walking straight.
8. Generally, use the left hand for steering and guiding the machine.
9. Always use ultra-high speed Polish on the floor.
10. Walk at a comfortable walking speed.
11. Never use the machine on the same spot for an extended period, as being a high speed machine the combination of friction and heat could strip or damage the floor unintentionally.
12. The appliance is not intended for use by young children or infirm persons without supervision.
13. Young children should be supervised to ensure that they do not play with the appliance.
14. If supply cord is damaged, it must be replaced by the manufacturer or it's service agent or a similarly qualified person to avoid a hazard.



## Dominator - SL1600

### Drive & Base Assembly - Part List

No	Code	Description
1	SLB000	Body
2	SLB006	Shaft-Drive Pulley
3	VPV230	Bearing
4	SLB005	Drive Pulley
5	GAS031A	Circlip
6	GAS031B	Circlip
7	AAG470	Washer 1/2" x 1" Zinc Bright
8	GAS054	Washer Spring 1/2" x 3/16" x 1/8"
9	GAS086	Setscrew 1/2X1 1/4 ZP HX
10	SLB018	Vac Chamber
11	SLB015	Shaft-Vac Pulley
12	GAS049	Bolt-Vac System Shaft 5/16" x 3/4"
13	GAS045	Washer Spring 5/16" x 1/8" x 3/32"
14	AAG385	Washer 5/16" x 7/8" Zinc Bright 16G
15	SLB013	Fan Boss
16	VPV252	Fan Blades (Pkt. of 12)
17	SLB014	Pulley Vac
18	SLB016	Bearing
19	SLB050	Circlip
20	SLB017	Circlip
21	SLB012	Vac Chamber Gasket 6.4mm x 9mm
22	SLB010	Pulley-Motor
23	SLB029	Drive Belt
24	SLB004	Tension Bracket
25	AAG365	Washer Flat 5/16" x 3/4" Zinc
26	SK006	Bolt-Motor MNT/Tension

# Dominator Burnisher- SL1600

## Drive & Base Assembly - Part List

No	Code	Description
27	SLB030	Bolt-Tensioner 1/4" x 2-1/2" BSW SS ZP
28	AAG236	Washer 1/4" x 5/8" Zinc Bright
29	SLB031	1/4" Nut
30	SLB002	Wheel & Bracket Assy.
31	SLB043	Hex Nut 5/16" - 18UNC
32	SLB036	Grub Screw 1/4X1/2
33	GAS205	Base Pad Assembly
34	SLB046	Screw Self Tapper 8AB X 5/8
35	SLB056A	Pad Clip
36	MS001	Bolt SS 1/2" x 3 Z/P 4mm HXHD
37	VPV166	Wheel
38	AAG470	Washer 1/2" x 1" Zinc Bright
39	GAS054	Spring Washer 1/2" x 3/16" x 1/8"
40	SLB045	Locknut 1/2" BWNN
41	P40JACKARO	Jackaroo 40 cm Pad
42	MS003	Skirt White 87mm width
43	MS004	Skirt Support SL1600
44*	VPV094	Hose Clamp
45	VPV058	Hose Dustbag
46	SLB044	Bolt-Handle Retain 1/2" x 1.3/4" Zinc
47	VPV156	Ring
48	VPV051	Dustbag Closure
49	VPV063	Dust Bag
50	SLB001CMG	Motor CMG
51	SLB011	3/16 Keyway
52	SLB055	Lift Handle

## Dominator - SL1600

### Drive & Base Assembly - Part List

No	Code	Description
53	VPA821	Roller Pin
54	SK016	Ratchet Lever
55	VPA782	Spacer-Torsion Spring
56	SLB028	Torsion Spring
57	AAD061	Bolt
58	SLB033	Set Screw
59	SLB039	Washer Flat
60	SLB038	Locknut
61	AAA584	Set Screw 1/4" x 1" Zinc
62	206784	Spacer
63	SLB040	Washer Flat
64	AAF140	Nut Nyloc 1/4" UNC
65	LAB011	Label
66	LAB002	Motor Label
67	GAS055	Short Nut
68	PPR002	Continental Trim
69	AAA628	Screw Coupling Retain
70	SLB036	Grubscrew
71	AAD041	Bolt
72	SLB035	Rivet ASL 5-6



# Rotary Scrubber - Shark / Stingray / Dominator

## SK034C Handle

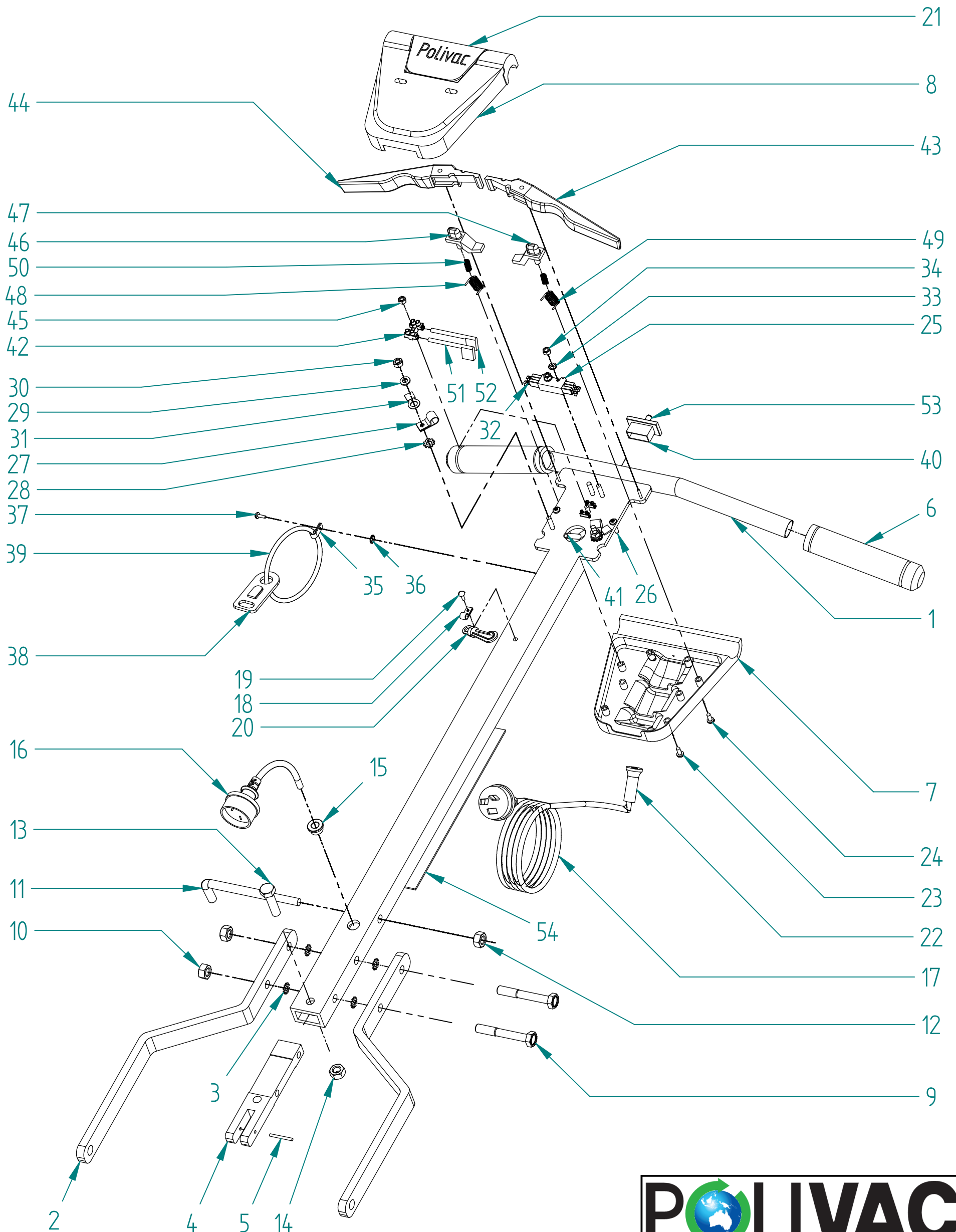

# Rotary Scrubber - Shark / Stingray / Dominator

## SK034C Handle - Part List

No	Code	Description
1	VPV611	Handle Stem
2	SK034A	Fork
3	AAJ460	Star Washer
4	VPA231	Tongue Assy
5	VPA821	Roll Pin
6	VPV605	Handle Grips
7	VPV601	Rear cover
8	VPV600	Front Cover
9	AAD039	Bolt
10	AAF140	Nut Nyloc 1/4" UNC
11	VPA765	Lead Hook
12	AAF140	Nut Nyloc 1/4" UNC
13	AAD041	Bolt
14	AAF140	Nut Nyloc 1/4" UNC
15	VPA841	Grommet
16	VPA618	Stem Lead Assy
17	VPV475	Mains Lead Assy (15m)
18	PVS070	Plastic Clamp
19	AAK829	Pop Rivet
20	VPV120	Dust Bag Hook
21	VPV607	Polivac Handle Label
22	ECG157	Lead Protector
23	AAA523	Screw
24	AAA522	Screw
25	VPA631	Cherry Switch
26	AAA525	Screw



# Rotary Scrubber - Shark / Stingray / Dominator

## SK034C Handle - Part List

<b>No</b>	<b>Code</b>	<b>Description</b>	<b>No</b>	<b>Code</b>	<b>Description</b>
27	VPA622	Clamp	53	ZDR078	Neon Indicator
28	AAJ451	Star Washer	54	VPV562	Label
29	AAG150	Washer			
30	AAE271	Nut			
31	AAM702	Earth Terminal			
32	AAM704	Flag Terminal			
33	AAJ002	Star Washer			
34	AAE200	Nut HVHD 1/8" ZP Pressed			
35	VVA019	Clamp			
36	AAJ451	Star Washer			
37	AAK829	Pop Rivet			
38	BV8003	Strain Relief			
39	BV8004	'O' Ring			
40	VPA639	Cap			
41	VPA926	Sleeve Insulation			
42	AAM601	Terminal Block			
43	VPV602	Left Trigger			
44	VPV603	Right Trigger			
45	AAE200	Nut HVHD 1/8" ZP Pressed			
46	VPV604R	Safety Button Right			
47	VPV604L	Safety Button Left			
48	VPA632R	Spring Right			
49	VPA632L	Spring Left			
50	VPV606A	Spring			
51	VPA626	Blue Wire			
52	VPA628	Brown Wire			

# SLB001CMG MOTOR

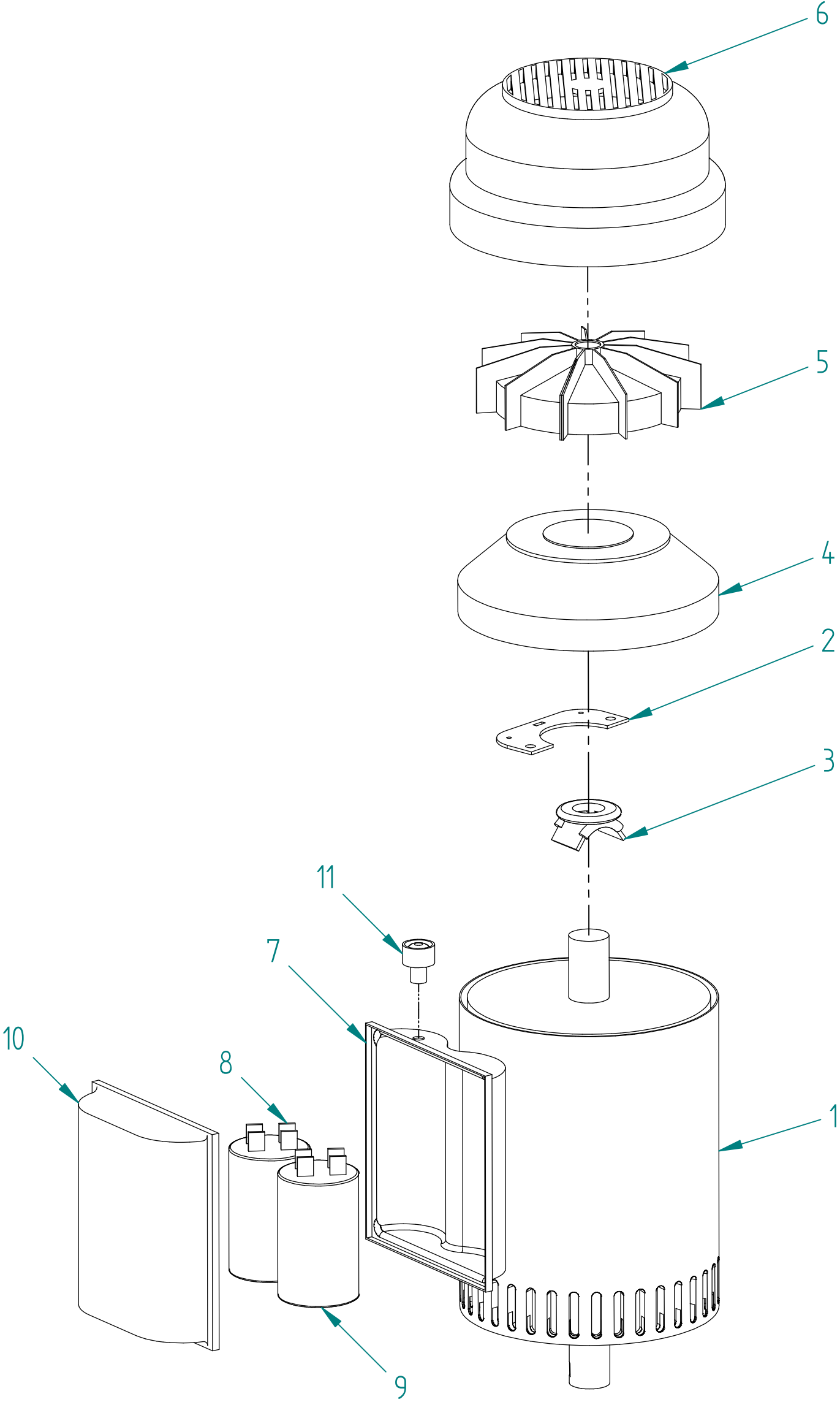

# SLB001CMG MOTOR

## Parts List

<b>No</b>	<b>Code</b>	<b>Description</b>
1	VPV810CMG	Flanged Endshield
2	VPV805CMG	Switch Plate
3	VPV806CMG	Centrifugal Switch
4	VPV811CMG	Non Drive Endshield
5	VPV812CMG	Cooling Fan
6	VPV813CMG	Cowl
7	VPV817CMG	Capacitor Box Base
8	VPV804CMG	Start Capacitor
9	VPV803CMG	Run Capacitor
10	VPV818CMG	Capacitor Box Lid
11	VPV807CMG	Manual Reset

# WARRANTY POLICY

1. When a warranty repair is requested, the purchaser must first contact any of Polivac's authorized Service Centres with proof of purchase and details of the alleged defect. In most instances, the request for warranty brought to the attention of our Service Centres or Agents is handled in a prompt routine manner with no question as to its validity. However, some requests for warranty are not justified. In these cases, product owners will be made aware that the premature failure of their product was the result of a cause not covered by Warranty.
2. The Polivac warranty covers only DEFECTIVE MATERIAL and/or DEFECTIVE WORKMANSHIP. It does not cover labour.
3. Polivac products are warranted for twelve (12) months from date of purchase by the original purchaser against faulty workmanship or material. The warranty covers only the replacement, repair or adjustment of any part which in the opinion of Polivac fails because of a fault in materials or workmanship:
  - a) drive motors and gearbox assemblies on electrical products carry a two (2) years warranty
  - b) bodies of carpet extraction products and vacuum cleaners carry a three (3) years conditional warranty.
  - c) battery warranty of twelve (12) months is as provided by the manufacturer. Terms available on request.
4. Where the product has been rented out by a Hire or similar company, the warranty period is reduced to three (3) months.
5. This warranty does not cover service calls, travelling time or consumable parts - e.g. drive belts, chains, flexible skirts or hoses, dust bags, mains leads, brushes, buffers, buffer strips, sanding discs, light bulbs, nozzles, filters, pressure pumps, piston seals, diaphragms, squeegees and like items.
6. In the case of proprietary components used by the manufacturer in the product, such as engines, electrical motors, chargers and the like, Polivac will pass on any warranty provided by the manufacture of such items.
7. Accidental damage, abuse, misuse or neglect of the product is not covered by warranty.
8. Fair wear and tear and where the product has been used other than for the purpose for which it was designed is not covered by warranty.
9. Use of non-approved chemicals and detergents in the product will void the warranty.
10. Products that have been modified are not covered by warranty.
11. Products that have not been serviced at their recommended intervals by an authorised Polivac Service Centre or Agent are not covered by warranty
12. Damage to, or failure of, the product which has resulted from low or high voltage, the use of an incorrectly sized extension lead, or a coiled electrical extension lead is not covered by warranty.
13. Repairs carried out on the product by any person other than an authorized Polivac repairer will void the warranty.
14. All freight charges to and from the manufacturer, agent or service centre will be the responsibility of the distributor.
15. A charge for traveling time and labour will be applicable for on-site warranty service.
16. Polivac reserves the right to replace defective parts of the product with parts or components of similar quality, grade and composition where an identical part or component is not available. Goods presented for repair may be replaced by refurbished goods of the same type rather than being repaired.

**POLIVAC WARRANTY IS SUBJECT TO THE LAWS AND REGULATIONS OF THE INDIVIDUAL STATES AND COMMONWEALTH TERRITORIES OF AUSTRALIA. THIS WARRANTY IS NOT TRANSFERRABLE.**

