



POLIVAC SANDIVAC SV25 LOW SPEED FLOOR SANDER



Operations Manual & Trouble-Shooting Guide

How to Operate a Sandivac SV25 or SV30



Please find the following correct procedure for the operation of the Polivac SV25 or SV30 Sander

1. Plug in power cable. Power supply will be visible via the neon indicator at the power plug and also the red light on the handle.
2. Tilt the machine back by using the handle.
3. Place the sanding disc onto the pad to the pad holder
4. Once the Disc is fitted stand the machine back up.
5. Slightly lift the handle up, and manoeuvre the wheels backwards and up out of the way (the wheels must be off the floor when sanding).
6. The handle height must be adjusted to suit individual operators body proportions. Adjust the ergo handle, to the correct height by placing your foot or hand on the ratchet lever then positioning the handle. The correct height of the handle is around the groin region.
7. When the handle is set at the correct height, the arms should grip the handle in a comfortable, but loose manner (if your arms are bent at the elbows this is an indication that you are applying too much effort to control the machine) Readjust the handle.
8. To start the machine, first you must disengage the red safety button that is next to the hand trigger, then grasp either of the red triggers, and the motor will engage the brush. Do not force the trigger without first releasing the safety button as this will damage the safety release in the trigger mechanism. Once the machine is on, the safety button can be released.
9. To facilitate the correct swinging motion of the machine, tip or lift the handle slightly forward to get the sander to move right and lower the handle to get the machine to move towards the left. This requires minimal effort. So, if you are having difficulty controlling the machine, check that you have the handle set at the correct height or your pad holder or sanding disc mechanism is damaged.
10. To use the vacuum system whilst sanding, switch the vac motor to the on position. The vacuum will be activated upon starting the machine.

PV25 SV25 SV30 Drive & Base Assembly

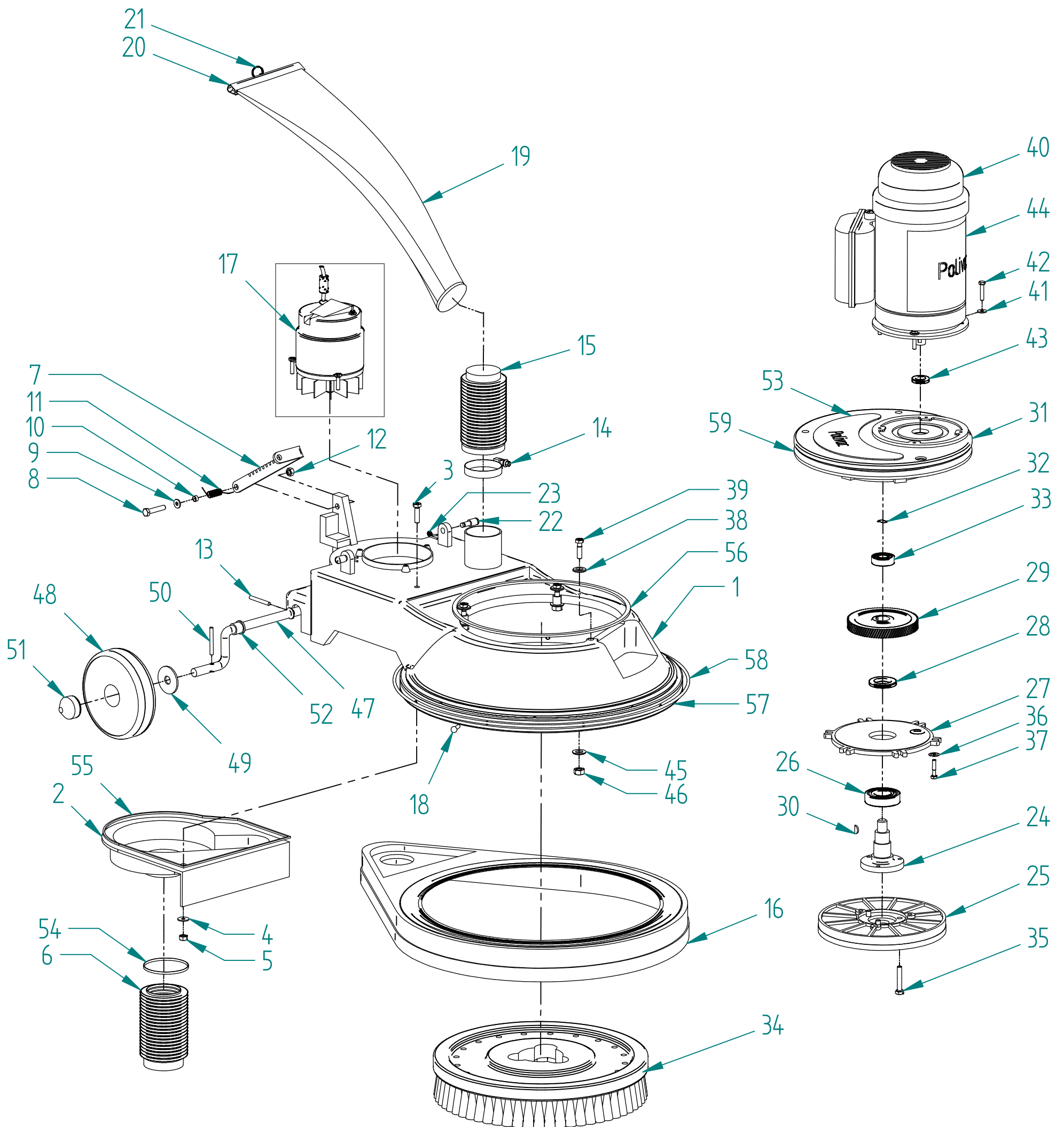

SV25 SV30

Drive & Base Assembly - Part List

No	Code	Description
1	VPV216	Skirt-Painted
2	VPV190	Fan Housing
3	AAA584	Set Screw 1/4" x 1" Zinc
4	AAG236	Washer 1/4" x 5/8" Zinc Bright
5	AAF140	Nut Nyloc 1/4" UNC
6	VPV008	Gaiter
7	VPA138	Lever-Ratchet
8	AAD061	Bolt 5/16" x 1.1/2" Zinc
9	AAG385	Washer 5/16" x 7/8" 16G Z/P
10	VPA782	Spacer
11	VPA139	Torsion Spring
12	SLB043	Nut Nyloc 5/16" UNC
13	VPV218	Retaining Pin-Axle
14	VPV094	Clamp-Hose Dust Bag
15	VPV058	Hose-Dust Bag
16	VPV090	Skirt Assy (PV25/PV25TS) for SV25/SV30 VPV090 BLK
17	VPV250	Vac Motor Complete
18	SLB035	Rivet ASL 5-6
19	VPV063BLK	Dust Bag Black color
20	VPV051	Closure-Dust Bag
21	VPV156	Bag Ring
22	VPA950	Handle Retaining Pin
23	VPA954	Clip
24	VPA116	Gear Shaft
25	VPA412	Quick Release Adaptor [PV25]
	VPA374	Brush Coupling [SV25,SV30] - Not Pictured



SV25 SV30

Drive & Base Assembly - Part List

No	Code	Description
26	VPA114	Bearing-Bottom
27	VPA113	Gear Cover
28	VPA118	Seal-Bottom
29	VPA411	Drive Gear
30	VFB115	Key
31	VPA495	Base Luggless
32	VPA121	Washer Wavy
33	VPA570	Bearing-Top
34	VI40I6	Pad holder with clutch
35	AAA628	Cap Screw 5/16" x 1" Socket HD [PV25]
	AAA635	Cap Screw 5/16" x 3/4" Socket HD [SV25,SV30]
36	VPA122	Washer TAB 1/2" OD x 1/4" ID
37	AAA564	Bolt 1/4" NC x 3/4" Zinc High Intensity
38	AAG236	Washer 1/4" x 5/8" Zinc Bright
39	AAD041	Bolt 1/4" x 1.1/4" Zinc
40	VPA975CMG	Motor [PV25]{VPV525CMG - Motoring gearbox}
	VPA011CMG	Motor [SV25]{VPV522CMG - Motoring gearbox}
	VPA013CMG	Motor [SV30]{VPV574CMG - Motoring gearbox}
41	AAG236	Washer 1/4" x 5/8" Zinc Bright
42	AAA564	Bolt 1/4" NC x 3/4" Zinc High Intensity
43	VPA104	Oil Seal Top
44	LAB001	Motor Label [PV25, SV25]
	LAB002	Motor Label [SV30]
45	AAG237	Washer 1/4" x 3/4" Zinc Bright 14x34 BSWZ
46	AAF140	Nut Nyloc 1/4" UNC
47	VPV170	Axle
48	VPV166	Wheel-Rubber Tyre
49	AAG470	Washer 1/2" x 1" Zinc Bright



SV25,SV30

Drive & Base Assembly - Part List

No	Code	Description
50	VPA355	Roll Pin 3/32" x 7/8" ZP
51	GCA292	Ratchet Cap 12mm
52	VWA634	Bush Nylon
53	LAB005	Label [PV25]
	LAB004	Label [SV25]
	LAB010	Label [SV30]
54	VPV459	Cable Tie
55	VPV106	Gasket 5mm x 9mm
56	VPV251	Gasket 10mm x 9mm
57	VPV087	Buffer-Skirt
58	VPV239	Insert-Buffer
59	VPA001	Weight [SV25, SV30]

VPV610 Handle

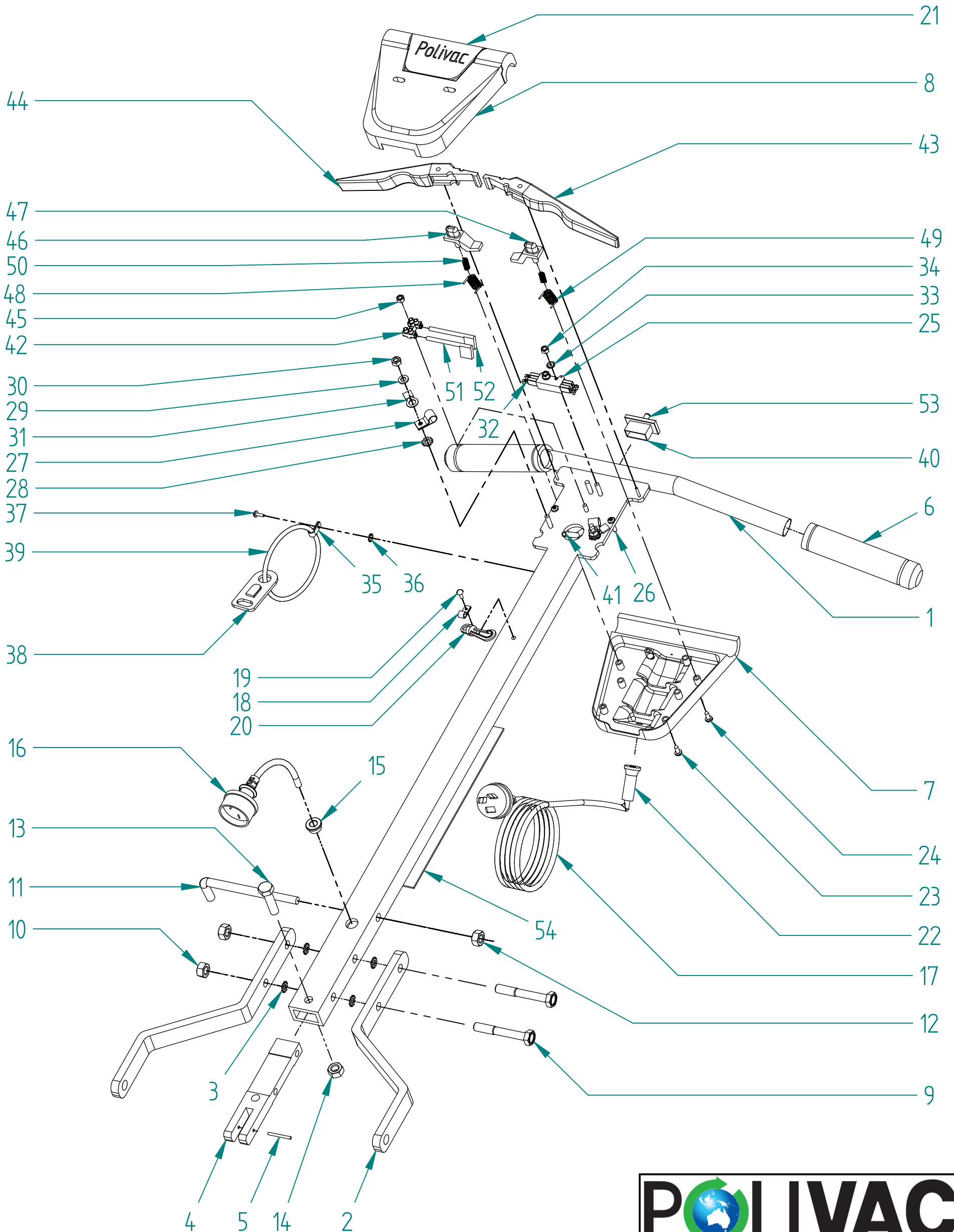

VPV610 Handle - Part List

No	Code	Description
1	VPV611	Handle Stem
2	VPA767	Fork
3	AAJ460	Star Washer
4	VPA231	Tongue Assy
5	VPA821	Roll Pin
6	VPV605	Handle Grips
7	VPV601	Rear cover
8	VPV600	Front Cover
9	AAD039	Bolt
10	AAF140	Nut Nyloc 1/4" UNC
11	VPA765	Lead Hook
12	AAF140	Nut Nyloc 1/4" UNC
13	AAD041	Bolt
14	AAF140	Nut Nyloc 1/4" UNC
15	VPA841	Grommet
16	VPA618	Stem Lead Assy
17	VPV475	Mains Lead Assy (15m)
18	PVS070	Plastic Clamp
19	AAK829	Pop Rivet
20	VPV120	Dust Bag Hook
21	VPV607	Polivac Handle Label
22	ECG157	Lead Protector
23	AAA523	Screw
24	AAA522	Screw
25	VPA631	Cherry Switch
26	AAA525	Screw

VPV610 Handle - Part List

No	Code	Description	No	Code	Description
27	VPA622	Clamp	53	ZDR078	Neon Indicator
28	AAJ451	Star Washer	54	VPV562	Label
29	AAG150	Washer			
30	AAE271	Nut			
31	AAM702	Earth Terminal			
32	AAM704	Flag Terminal			
33	AAJ002	Star Washer			
34	AAE200	Nut HVHD 1/8" ZP Pressed			
35	VVA019	Clamp			
36	AAJ451	Star Washer			
37	AAK829	Pop Rivet			
38	BV8003	Strain Relief			
39	BV8004	'O' Ring			
40	VPA639	Cap			
41	VPA926	Sleeve Insulation			
42	AAM601	Terminal Block			
43	VPV602	Left Trigger			
44	VPV603	Right Trigger			
45	AAE200	Nut HVHD 1/8" ZP Pressed			
46	VPV604R	Safety Button Right			
47	VPV604L	Safety Button Left			
48	VPA632R	Spring Right			
49	VPA632L	Spring Left			
50	VPV606A	Spring			
51	VPA626	Blue Wire			
52	VPA628	Brown Wire			

Drive Motor

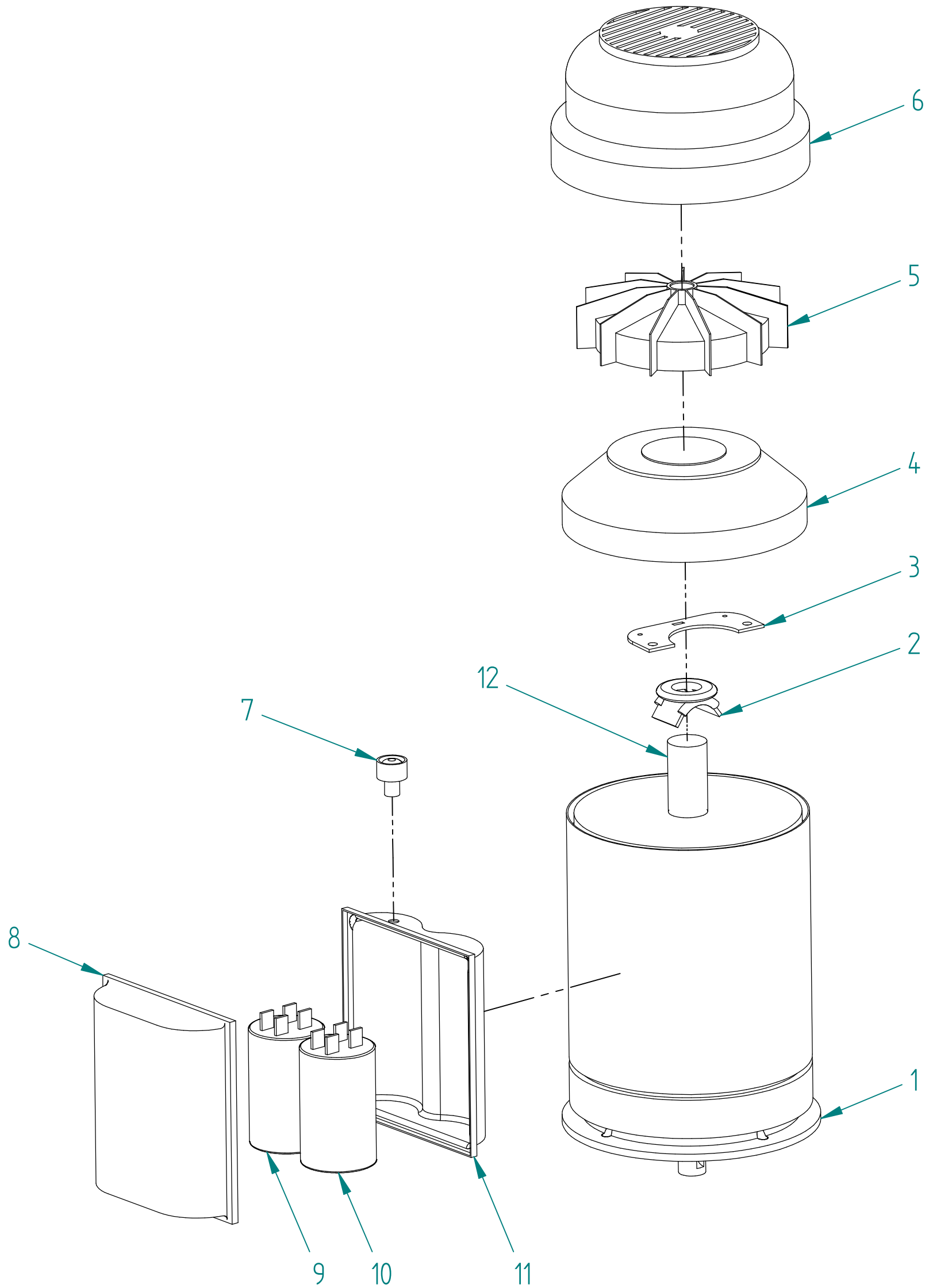

Drive Motor Parts List

No	Code	Description
1	VPV810CMG	Range Endshield (Drive End)
2	VPV806CMG	Centrifugal Switch
3	VPV805CMG	Switch Contact Plate
4	VPV811CMG	Non Drive Endshield
5	VPV812CMG	Cooling Fan
6	VPV813CMG	Cowl
7	VPV807CMG	Manual Reset
8	VPV818CMG	Capacitor Box Lid
9	VPV822CMG	Run Capacitor
10	VPV797CMG	Start Capacitor
11	VPV817CMG	Capacitor Box Base
12	VPV224CMG	Rotor (Coro & Shaft) - Not Available as spare part

Vacuum Motor

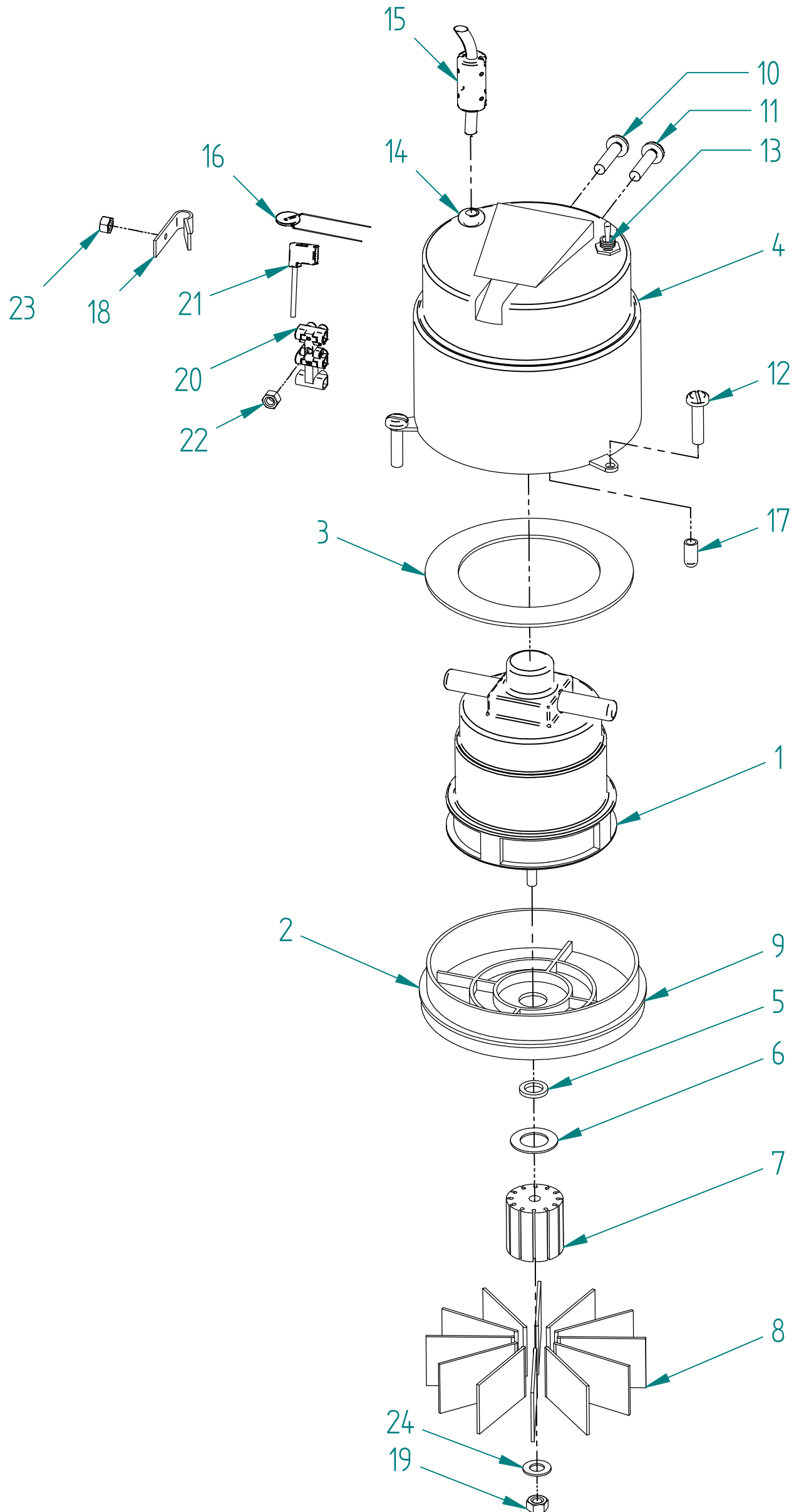

Suction Polisher - PV 25 SV25 SV30

Vacuum Motor - Part List

No	Code	Description
1	VPV306	Vacuum Motor
	VPV248(Vac Motor and fan Assembly)	VPV250(Complete Vac Motor
2	VPV188	Motor Support Base
3	VPV192	Baffle
4	VPV213	Vaccum Motor Cowl
5	VPV198	Spacer
6	AAG385	Washer 5/16 x 7/8 Zinc Bright 16G
7	VPV184	Fan Boss
8	VPV252	Fan Blade (Pkt. of 12)
9	VPV976	Vac Support Seal 450mm
10	VVA171	Screw 1/8 x 3/4 BSW Z/P Phillips HVRH
11	VPV193	Screw Nylon
12	AAA700	Screw 14 x 3/4 Thread Cutting Z/P
13	VPV191T	Vacuum Motor Switch
14	VPA837	Lead Grommet
15	VPV001	Ferrite
16	VPV002	Ceramic Capacitor
17	VPV195	Spancer Grommet
18	VVA019	Clamp-Cord
19	AAE413	Nut 1/4 Locknut BSW Thread Z/H
20	AAM601A	Terminal Block
21	VPA628	Wire Brown
22	AAE200	Nut HVHD 1/8" ZP Pressed
23	VPV194	Nylon Nut M5
24	AAG360	Washer 1/4 x 7/8 x 18 ZP



WARRANTY POLICY

1. When a warranty repair is requested, the purchaser must first contact any of Polivac's authorized Service Centres with proof of purchase and details of the alleged defect. In most instances, the request for warranty brought to the attention of our Service Centres or Agents is handled in a prompt routine manner with no question as to its validity. However, some requests for warranty are not justified. In these cases, product owners will be made aware that the premature failure of their product was the result of a cause not covered by Warranty.
2. The Polivac warranty covers only DEFECTIVE MATERIAL and/or DEFECTIVE WORKMANSHIP. It does not cover labour.
3. Polivac products are warranted for twelve (12) months from date of purchase by the original purchaser against faulty workmanship or material. The warranty covers only the replacement, repair or adjustment of any part which in the opinion of Polivac fails because of a fault in materials or workmanship:
 - a) drive motors and gearbox assemblies on electrical products carry a two (2) years warranty
 - b) bodies of carpet extraction products and vacuum cleaners carry a three (3) years conditional warranty.
 - c) battery warranty of twelve (12) months is as provided by the manufacturer. Terms available on request.
4. Where the product has been rented out by a Hire or similar company, the warranty period is reduced to three (3) months.
5. This warranty does not cover service calls, travelling time or consumable parts - e.g. drive belts, chains, flexible skirts or hoses, dust bags, mains leads, brushes, buffers, buffer strips, sanding discs, light bulbs, nozzles, filters, pressure pumps, piston seals, diaphragms, squeegees and like items.
6. In the case of proprietary components used by the manufacturer in the product, such as engines, electrical motors, chargers and the like, Polivac will pass on any warranty provided by the manufacture of such items.
7. Accidental damage, abuse, misuse or neglect of the product is not covered by warranty.
8. Fair wear and tear and where the product has been used other than for the purpose for which it was designed is not covered by warranty.
9. Use of non-approved chemicals and detergents in the product will void the warranty.
10. Products that have been modified are not covered by warranty.
11. Products that have not been serviced at their recommended intervals by an authorised Polivac Service Centre or Agent are not covered by warranty
12. Damage to, or failure of, the product which has resulted from low or high voltage, the use of an incorrectly sized extension lead, or a coiled electrical extension lead is not covered by warranty.
13. Repairs carried out on the product by any person other than an authorized Polivac repairer will void the warranty.
14. All freight charges to and from the manufacturer, agent or service centre will be the responsibility of the distributor.
15. A charge for traveling time and labour will be applicable for on-site warranty service.
16. Polivac reserves the right to replace defective parts of the product with parts or components of similar quality, grade and composition where an identical part or component is not available. Goods presented for repair may be replaced by refurbished goods of the same type rather than being repaired.

POLIVAC WARRANTY IS SUBJECT TO THE LAWS AND REGULATIONS OF THE INDIVIDUAL STATES AND COMMONWEALTH TERRITORIES OF AUSTRALIA. THIS WARRANTY IS NOT TRANSFERRABLE.

